

**URGENT**  
**DEPARTMENT OF THE ARMY TECHNICAL BULLETIN**

---

**INSTRUCTIONS FOR UPGRADE OF  
ROTOR TRACK AND BALANCE ACCESSORY KIT  
AH-64A KITS/SETS**

---

**Headquarters, Department of the Army, Washington, D.C.  
15 March 2004**

---

**DISTRIBUTION STATEMENT A - Approved for public release; distribution is unlimited.**

**REPORTING ERRORS AND RECOMMENDING IMPROVEMENTS**

You can help improve this manual. If you find any mistakes or if you know of a way to improve the procedures, please let us know. Mail your letter or DA Form 2028 (Recommended Changes to Publications and Blank Forms) directly to Commander, U.S. Army Aviation and Missile Command, ATTN: AMSAM-MMC-MA-NP, Redstone Arsenal, AL 35898-5000. A reply will be furnished to you. You may also provide DA Form 2028 information to AMCOM via e-mail, fax, or the World Wide Web. Our fax number is: DSN 788-6546 or Commercial 256-842-6546. Our e-mail address: [2028@redstone.army.mil](mailto:2028@redstone.army.mil). Instructions for sending an electronic 2028 may be found at the back of this manual. For the World Wide Web use: <https://amcom2028.redstone.army.mil>.

**TB 1-1520-238-20-137**

**1. GENERAL INFORMATION.**

ACCESSORY KIT, ROTOR TRACK & BALANCE			ACCESSORY KIT, ROTOR TRACK & BALANCE		
NSN: 4920-01-328-8013			NSN: 4920-01-517-3110		
P/N: 7-26210008-613			P/N: 7-26210008-615		
Remove			Add		
P/N NSN	ITEM	QTY	P/N NSN	ITEM	QTY
7-262110079 1615-01-249-4000	Cable, Umbilical	1	7-562117009-001 None	Bracket, Accel-Clutch-APU-AVA	1
7-262110037 1680-01-253-2888	Target Set, Blade Tip, MR Track & Balance	1	7-562110073-603 None	Container, Handling/Storage Rotor Track&Bal	1 Note1
7-362100092 6150-01-474-8680	Cable Assy, Extension	1	7-562110225-601 4920-01-474-8671	Adapter, Laser, Acc Kit-Rtr Track&Bal	1 Note2
7-362110211 TBD	Adapter, Power Cord- Tail Rotor Balancer	1	LAS-200-635-5 4920-01-474-5625	LAS Series Laser	1 Note2
			LS5 4920-01-476-7716	9 VDC Battery Supply	1 Note2
			LS6 None	Wall Transformer	1 Note2
			HS5572-0001 5340-01-471-1168	Plate, Assy, Component Listing	1
			HS5216-2 9905-01-471-3313	Plate, Identification	1

- 1.1** The APU Clutch Accelerometer AVA Bracket required to perform this modification has been provided by Boeing to the units (see table below) because of the SOF AH-64-04-01 and P00114. Units receiving these support equipment shall perform this modification. The data plates will re-identify the AH-64A/D Kit. All components removed from the kit shall be disposed as directed by USG.
- 1.2** For units with the 7-26210008-613 Rotor Track and Balance Accessory Kit with the 7-262110073-605 wooden Storage and Handling Container, cut a cavity 1" L X 1" W X 1" Deep at the approximate area shown in Figure 1 for the APU Clutch Accelerometer AVA Bracket.
- 1.3** For units with the 7-26210008-615 Rotor Track and Balance Accessory Kit with the 7-562110073-603 roto-molded polyethylene Storage and Handling Container, cut a cavity 2" L X 2" W X 12" Deep at the approximate area shown in Figure 2 for the 105R Laser. Container has a provision the LAS Laser and 7-562110225-601 Laser Adapter.

Note 1: 7-562110073-603 Rotor Track and Balance Accessory Storage and Handling Container is the preferred container for the 7-26210008-615 Rotor Track and Balance Accessory Kit. The 7-262110073-605 Rotor Track and Balance Accessory Storage and Handling Container is an alternate container.

Note 2: Support equipments above are the alternate equipments in the old 7-26210008-613 Rotor Track and Balance Accessory Kit. Equipments are a direct replacement of 105R Laser and 100B Battery Pack that are obsolete.

**For Kits with  
7-262110073-603 Container:**

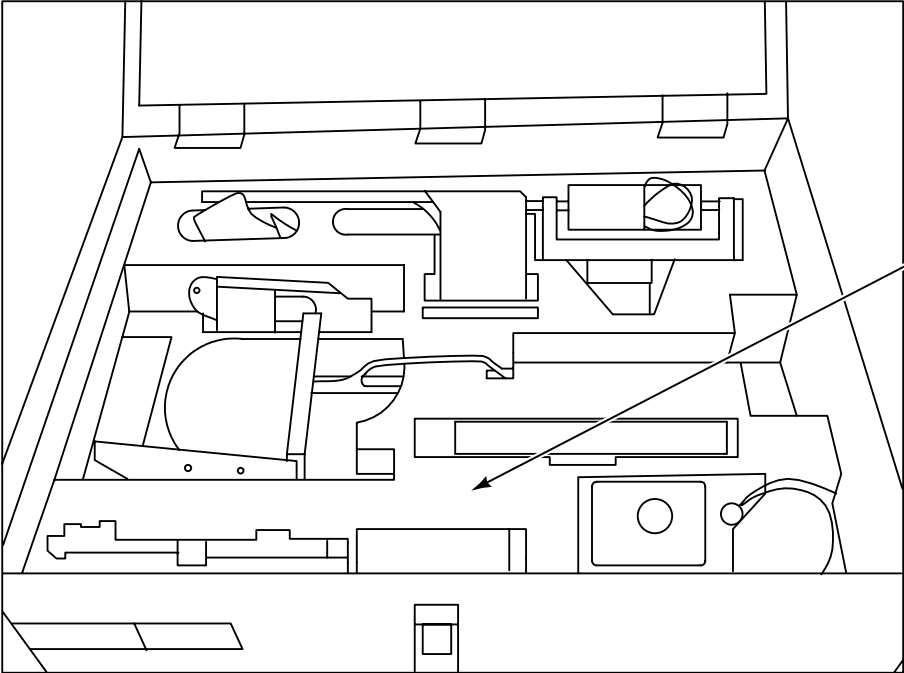

CUT A CAVITY 1" L X 1" W X 1" DEEP FOR THE BRACKET, ACCEL, APU CLUTCH

**Figure 1**

MS023149

**For Kits with  
7-562110073-603 Container:**

**TB 1-1520-238-20-137**

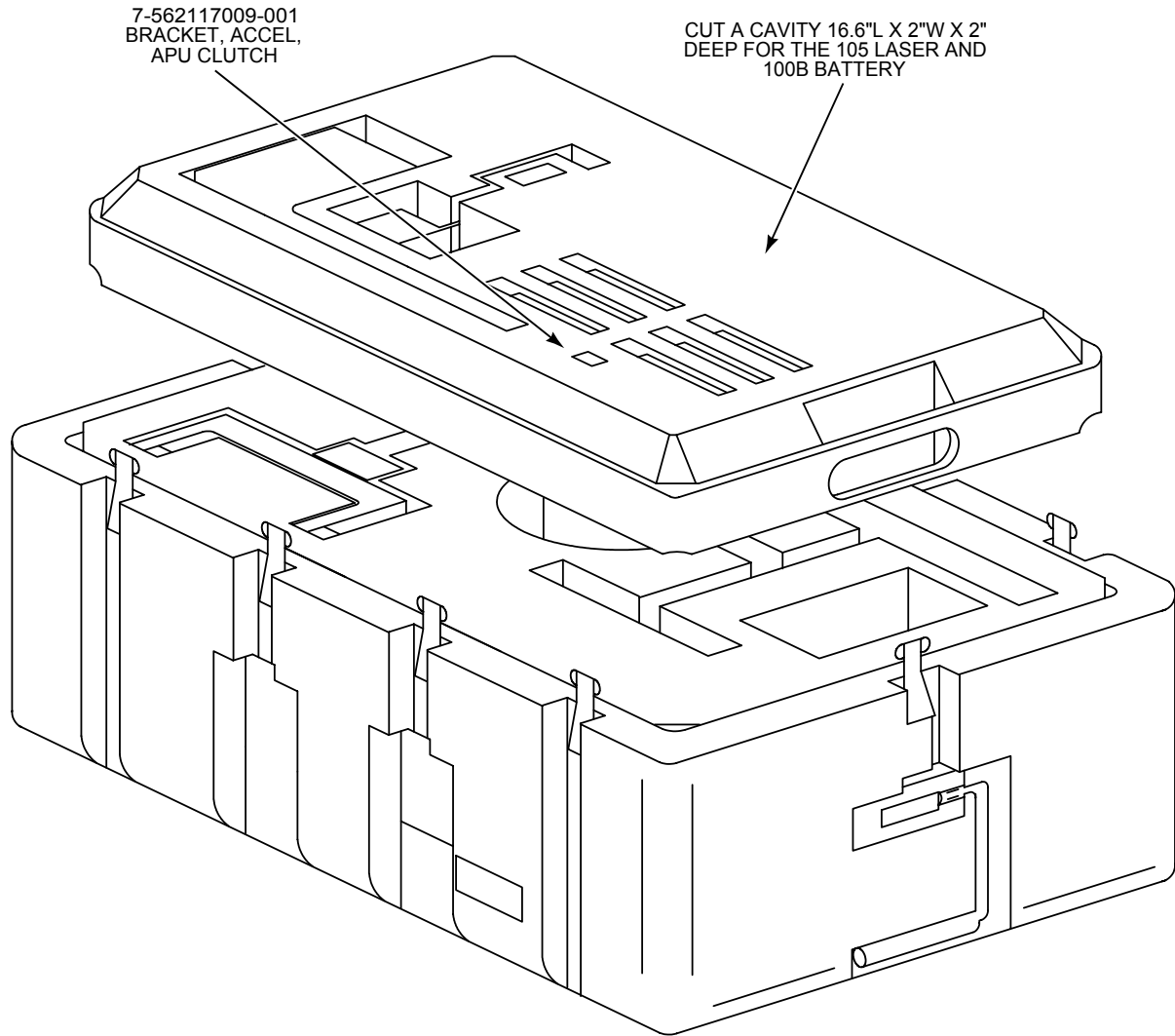

MS023150

**Figure 2**

The deployment of the APU Clutch Accelerometer AVA Bracket was done under the direction of the USG contracting officer.

The APU Clutch Accelerometer AVA Brackets were sent to the units below in support of SOF:

LOCATION	QUANTITY	LOCATION NG/AR	QUANTITY
1-227Avn, Ft. Hood	3	1-6 Cav, Korea	3
1-227Avn (Reset), Ft. Hood	3	1-183 Avn, IDNG	3
2-101 Avn, Iraq	3	1-1 Avn, Germany	3
1-3 Avn, HAAF, Ga	3	3-229 Avn, Ft. Bragg	3
1-3 Avn, (Reset) HAAF, Ga	3	1-151 Avn, SCNG/Kosovo	3
1-2 Avn, Korea	3	1-501 Avn, Iraq	3

## **TB 1-1520-238-20-137**

1-101 Avn, Iraq	3	7-6 Cav, TXAR	3
6-6 Cav, Iraq	3	USAAVNC, Ft. Rucker	3
1-4 Avn, Iraq	3	21Cav, Ft. Hood	3
3-6 Cav, Korea	3	1-135 Avn, MONG	3
1-285 Avn, AZNG	3	4-278 RAS, TNNG	3
3-101 Avn, Iraq	3	1-149 Avn, TXNG	3
1-229 Avn, Ft. Bragg	3	1-130 Avn, AFAN	3
2-6 Cav, Germany	3	1-111 Avn, FLNG	3
8-229 Avn, KYAR	3	1-211 Avn, UTNG	3
4-3 ACR, Iraq	3	WAATS, AZNG	3

**2. SUPPLY PARTS AND DISPOSITION:** Through normal supply channels.

**3. SPECIAL TOOLS:** N/A.

**4. APPLICATION:** AVUM.

**5. REFERENCES.**

TM 1-1520-238-23 Series.

**6. FORMS:** N/A.

**7. WEIGHT AND BALANCE:** N/A.

**8. POINTS OF CONTACT:**

Technical: Tom Downey, AMSAM-MMC-AV-AB, DSN 876-1322 or commercial (256) 313-1322.  
Logistics: Lloyd Hopkins, SFAE-AV-AAH-LF, DSN 876-4072 or commercial (256) 313-4072.

By Order of the Secretary of the Army:

Official:

**PETER J. SCHOOMAKER**  
General, United States Army  
Chief of Staff

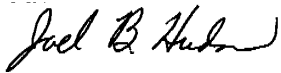

**JOEL B. HUDSON**  
Administrative Assistant to the  
Secretary of the Army  
0407603

**DISTRIBUTION:**

To be distributed in accordance with Initial Distribution Number (IDN) 314 113, requirements for TB 1-1520-238-20-137.

## ***These are the instructions for sending an electronic 2028***

The following format must be used if submitting an electronic 2028. The subject line must be exactly the same and all fields must be included; however, only the following fields are mandatory: 1, 3, 4, 5, 6, 7, 8, 9, 10, 13, 15, 16, 17, and 27.

From: "Whomever" [whomever@avma27.army.mil](mailto:whomever@avma27.army.mil)  
To: [2028@redstone.army.mil](mailto:2028@redstone.army.mil)  
Subject DA Form 2028

1. **From:** Joe Smith
2. **Unit:** home
3. **Address:** 4300 Park
4. **City:** Hometown
5. **St:** MO
6. **Zip:** 77777
7. **Date Sent:** 19-OCT-93
8. **Pub no:** 55-2840-229-23
9. **Pub Title:** TM
10. **Publication Date:** 04-JUL-85
11. **Change Number:** 7
12. **Submitter Rank:** MSG
13. **Submitter FName:** Joe
14. **Submitter MName:** T
15. **Submitter LName:** Smith
16. **Submitter Phone:** 123-123-1234
17. **Problem:** 1
18. **Page:** 2
19. **Paragraph:** 3
20. **Line:** 4
21. **NSN:** 5
22. **Reference:** 6
23. **Figure:** 7
24. **Table:** 8
25. **Item:** 9
26. **Total:** 123
27. **Text:**

This is the text for the problem below line 27.